



**JEFFERSON**  
COUNTY COLORADO

**STAFF BRIEFINGS and WORK SESSIONS**

**Hybrid Meeting**

**AGENDA**

**September 13, 2022, Meeting Will Begin Immediately Following BCC Hearings**

**BCC Boardroom, 5<sup>th</sup> Floor and WebEx Virtual Platform**

Join our virtual meeting via WebEx

<https://jeffco.webex.com/jeffco/onstage/g.php?MTID=e420ecb0cd735c25ceee27f24fb3615fd>

**Event Password:qfMS4XDzZ28**

Select the "Join by Browser" option

You can also join by telephone: Dial +1-408-418-9388;

**Access Code/Event Number: 2487 898 7851**

---

	<b>Pages</b>
<b>1. Briefing Items</b>	
1.1. Sheriff Request - American Rescue Plan Act - 2023 Detentions Staffing Funding presented by Chief Prata 5 minutes	3
1.2. License Agreement - Automatic License Plate Reader Devices within County Right-of-Way presented by Chief Pocsik and Steve Durian 20 minutes	6
1.3. License Agreement - Wildlife Fence within County Right-of-Way presented by Steve Durian 5 minutes	10
1.4. Appointments of Alternate Members to the Opioid Council presented by Eric Butler 5 minutes	11
1.5. 2022 Organization and Business Items Resolution for the Board of County Commissioners Modification presented by Deborah Churchill, Daniel Collins and Julie Story 5 minutes	12

2. **Reports**  
Commissioners  
  
County Manager  
  
County Attorney
3. **Executive Session**
  - 3.1. **Hughes v. BCC - Legal Advice C.R.S. 24-6-402(4) (b)**  
15 minutes
  - 3.2. **Workplace Investigation - Legal Advice C.R.S. 24-6-402(4) (b)**  
15 minutes
  - 3.3. **Legal Update - Legal Advice C.R.S. 24-6-402(4) (b)**  
10 minutes
4. **Adjourn**
5. **Work Sessions - No Agenda Items**

**BOARD OF COUNTY COMMISSIONERS BRIEFING PAPER**  
**American Rescue Plan – Federal Grant**  
**2023 Detentions Staffing Funding**  
**September 13, 2022**

- For Information                       For Discussion/Board Direction       Consent to  
Place on Business/  
Hearing Agenda

**Issue:** The Jefferson County Sheriff’s Office (JCSO) requests one-time American Rescue Plan Act (ARPA) funds in the amount of \$3.75 million for Fiscal Year (FY) 2023, in order to fund 40 detention center positions that are currently authorized but not funded in 2023.

**Background:** In 2018, the Board of County Commissioners (BCC) approved funding to fully open and staff the JCSO Detentions Center. Beginning January 2020, the JCSO budget was reduced by \$6.5 million. In addition to other service reductions, this resulted in closing one floor of the detention center and holding vacant 40 detentions staff positions needed to operate this floor.

In November 2020, the BCC approved one-time funding from the CARES ACT in the amount of \$3.75 million for 2021 and 2022, respectively, for a total of \$7.5 million, to hire 40 detention center FTE’s to address capacity needs during the COVID pandemic. The JCSO did not use any of the \$3.75 million earmarked for 2021, and does not expect to need to use the funding allocated in 2022. Although detentions staffing costs (including the work release program) exceeded the budget by over one million in 2021, and will exceed the budget again in 2022 by a similar amount, this amount was offset by savings in other JCSO divisions. These savings were realized due to vacancies created by recruitment and retention challenges in other divisions in the JCSO.

The JCSO is requesting American Rescue Plan Act (ARPA) funds in the amount of \$3.75 million for 2023, in order to continue to hire the 40 detention positions needed to operate a full floor of the jail. This request was briefed by the ARPA county team on August 9<sup>th</sup> 2022, with the recommendation to set aside \$3.75M ARPA funds to be used on an as-needed basis for detention facility staffing. The funds would only be utilized after the JCSO first uses all budget savings, and briefs the BCC at the end of the third quarter of 2023 regarding the status of savings and the subsequent need to use the earmarked APRA funds. Thus, the earmarked ARPA funds would only be used if the Sheriff exhausts all other savings within existing budget.

The need to adequately staff and fund the detention center in order to meet community safety needs is strongly supported by the jurisdictions that were surveyed by the county ARPA team when researching JCSO requests. Arvada, Edgewater, Golden, Lakewood, Westminster and Wheat Ridge all reported concerns around multiple challenges caused by lack of jail capacity to house inmates. Such concerns included refusal of actionable warrants to the jail, decreased morale among officers who apprehend criminals but have no jail space for them, and awareness among criminals that they may not be incarcerated for crimes.

**Discussion:** The average daily detention center population has increased 30% from the first half of 2021 to the first half of 2022, reaching over 1,000 inmates in July 2022. Current budgets are insufficient to provide the staffing needed to manage the inmate population and meet the needs of the county and its municipalities. There is growing concern that community safety is being compromised by the inability to house criminal offenders. Current overtime use is excessive and exhausting for existing staff, generating retention issues and producing a stressful work environment.

Before the 2020 budget cuts, the detention center population capacity was 1,392 inmates. To implement cuts, early releases occurred in order to reduce the population to a new target of 1,148 inmates. The COVID pandemic then imposed additional challenges on staffing needs, dictating a jail management use plan to further reduce the jail population and manage the space under social distancing requirements. In 2020, crime increased rapidly, continuing into 2021. This trend prompted a letter from the mayors demanding additional jail space be made available to address community safety needs.

The ongoing need for additional staffing budgets for the detention center is critical. Pandemic control measures are in place as a standard mode of operation in the detention center. In addition, the inmate population demographics have also changed. The types of inmates housed now include more individuals charged with violent crimes classified maximum security, and more individuals that require a restrictive housing setup. Increased security is critical in managing modules and common space areas like the kitchen. Inmate vs. staff assaults increased 200% from 25 incidents in 2018 to 75 incidents in 2021, and inmate on inmate assaults increased 33% from 2018 to 2021, despite a 35% reduction in the jail population during this time.

The ARPA funding would allow the JCSO to continue detention center staffing operations in 2023, while a permanent solution is found to restore ongoing funding for the 40 detention center positions. Not funding this request will cause an immediate public safety risk. A new administration will be faced with these challenges in January 2023.

**Fiscal Impact:**

Year of impact: 2023

TABOR impact: No TABOR impact because the funds spent are federal revenue.

Existing grant or project: County-direct ARPA award

New grant or project: None

Requested in adopted budget: No

Ongoing or one-time: One-time (2023 FY)

General Fund impact: None

Staffing impact: N/A (no new positions are authorized; the 40 positions exist but are not funded).

ARPA impact: \$3.75 million of the county-direct ARPA award will be used to fund the 40 detentions positions in 2023, with a planned US Treasury category of "supporting public sector capacity."

Match requirements: None

Mandate/Contractual obligation: Public safety mandate

**Revenue Limits Impact:** yes no

These are federal funds, so there is no impact to the TABOR fiscal year spending limit.

**SPA Review:** Support, no concerns

**Facilities Review:** Does not apply/no fiscal impact

**BIT Review:** County IT expects a cost increase in enterprise systems licensing costs of approximately \$15,000 for the year, due to the addition of 40 new individuals to staffing. Licensing costs are not based on authorized FTE, but on actual individuals employed, so increasing employee count will result in additional licensing costs for enterprise systems.

**Fleet Review:** Does not apply/no fiscal impact

**Human Resources Review (new FTE only):** N/A

**Recommendations:** The JCSO recommends that the Board of County Commissioners support the detention staffing ARPA funding request for 2023 and move it forward to the hearing consent agenda for formal approval.

**Originator:** Adriana Prata, Division Chief, Financial and Information Services Division, Sheriff's Office, aprata@jeffco.us or 720-512-0416

**Contacts for Additional Information:**

Adriana Prata, Division Chief, Financial and Information Services Division, Sheriff's Office, aprata@jeffco.us or 720-512-0416

JD Jepkema, Division Chief, Support Services Division, Sheriff's Office, jdjepkema@jeffco.us or 720-355-3618

**BOARD OF COUNTY COMMISSIONERS BRIEFING PAPER**  
**License Agreement for the use of Automatic License Plate Reader**  
**Devices within County Rights-of-Way**  
**September 13, 2022**

- For Information                     
 For Discussion/Board Direction                     
 Consent to Place on Business/  
Hearing Agenda

**Issue:** The Sheriff’s automatic license plate reader (ALPR) technology contract requires cameras in county right-of-way. Prior to installation within County rights-of-way, the Board of County Commissioners are required to approve a license agreement which would be administered by the Transportation and Engineering Division.

**Background:** Year to date, the Sheriff’s Office has seen a 136% increase on motor vehicle theft since 2019. This trend is also consistent with motor vehicle theft in the Denver Metro Area. A challenge for law enforcement agencies is being able to identify stolen vehicles.

Flock Group Inc. provides automatic license plate reader (ALPR) technology to law enforcement. ALPR cameras captures license plates and alerts law enforcement agencies of reported stolen vehicles. Flock Group offered the Sheriff’s Office an opportunity to deploy up to 25 cameras at no cost during a one-year pilot program. The cameras will be installed in pre-determined roadway locations in unincorporated Jefferson County.

ALPR camera technology is used by many agencies throughout the country. ALPR cameras are instrumental in recovering stolen vehicles and arresting suspect.

**Discussion:** The Sheriff’s Office has already entered into an agreement with Flock Technologies. The Sheriff will use any data from the cameras for the recovery of stolen vehicles. All data gathered by the cameras is the property of the County and requires Sheriff approval prior to any other use. A county license agreement is required to locate these cameras in County right-of-way. Once license agreements are signed, Flock will install up to 25 cameras in the right of way of county-maintained roads. See attachment for a map of proposed installation locations and a detail of the installation. The locations have been determined based on a higher number of motor vehicle theft incidents.

T&E staff has reviewed the requested locations and has concluded that there is sufficient right of way for these camera installations and that their locations will not interfere with road operations.

**Fiscal Impact:** The license agreements will have no fiscal impact to the County.

**Revenue Limits Impact:** yes no

**SPA Review:** No concerns

**Facilities Review:** N/A

**BIT Review:** N/A

**Fleet Review:** N/A

**Human Resources Review (new FTE only):** N/A

**Recommendations:** Recommend that staff bring the license agreement for the use of ALPR cameras within County rights-of-way to a future business agenda.

**Originator:** Scott Pocsik, Patrol Division Chief  
Steve Durian, Transportation & Engineering Director

**Contacts for Additional Information:**  
Scott Pocsik, Patrol Division Chief  
Steve Durian, Transportation & Engineering Director

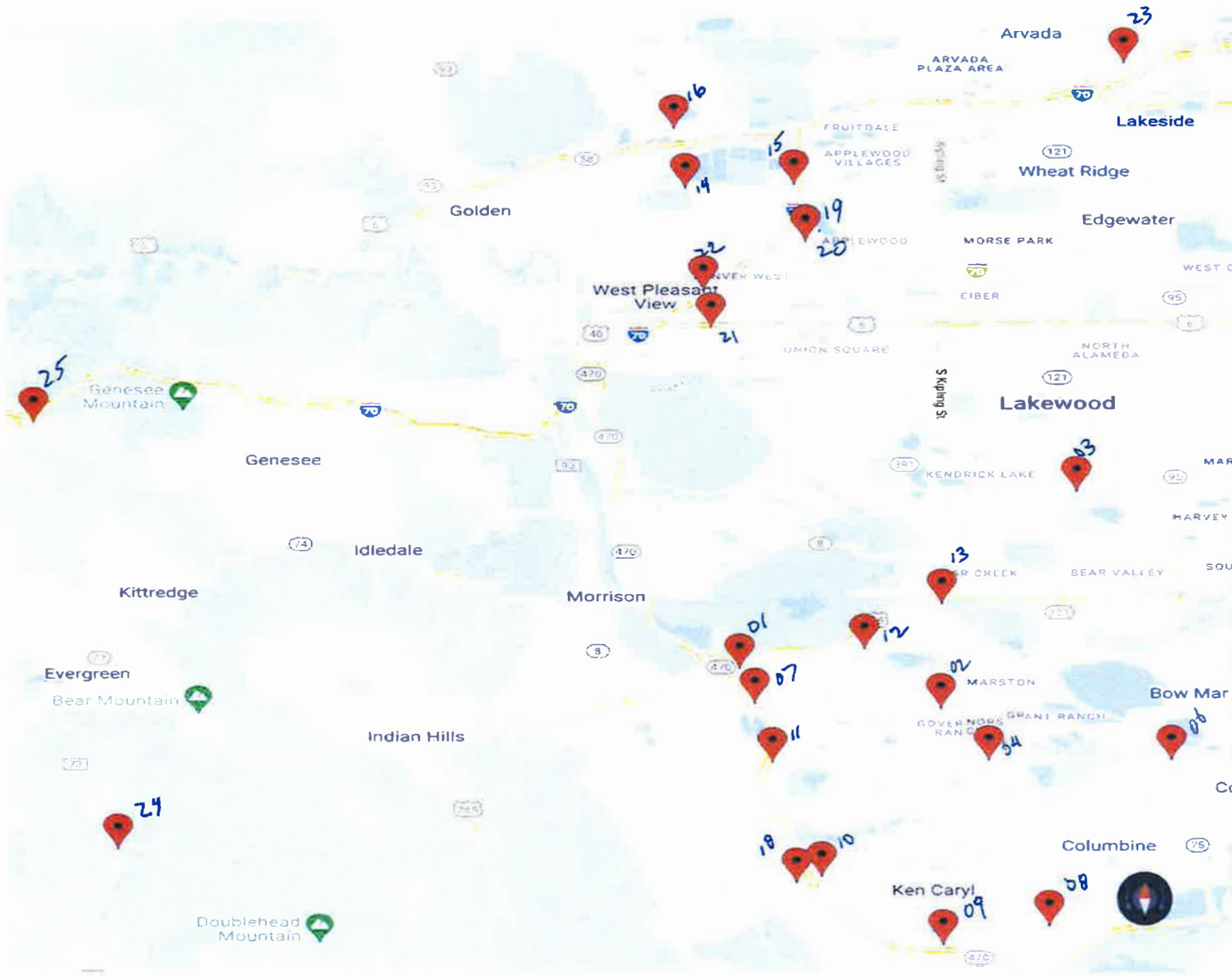

# flock safety

PROJECT:	CO - Jefferson County SO
DATE:	4/12/2022
NUMBER OF LOCATIONS:	23
SUBMITTED BY:	Veronica Cooley
EMAIL:	<a href="mailto:permit@flocksafety.com">permit@flocksafety.com</a>
PHONE:	(415)669-0341
LIST OF LOCATIONS:	<ul style="list-style-type: none"> <li>✓ 01 NB Home Depot Entrance Tufts and Quincy</li> <li>✓ 02 SB Kipling at Belleview</li> <li>✓ 03 SB Upham at Pierce</li> <li>✓ 04 Flower and Bowles (Mal) Ent</li> <li>✓ 05 WB Bowles at Sheridan</li> <li>✓ 07 SB Quincy @ Belleview</li> <li>✓ 08 WB Chatfield at Wadsworth</li> <li>✓ 09 NB Kipling at C-470</li> <li>✓ 10 EB Ken Caryl Ave at C-470</li> <li>✓ 11 EB W Bowles at C 470</li> <li>✓ 12 SB S. Simms @ Quincy</li> <li>✓ 13 SB Kipling at W Hampden</li> <li>✓ 14 EB W 32nd at McIntyre</li> <li>✓ 15 WB W 32nd at Zinnia</li> <li>✓ 16 NB McIntyre at W 44th</li> <li>✓ 18 WB W Ken Caryl at 470</li> <li>✓ 19 W 20th at Youngfield</li> <li>✓ 20 SB Youngfield at W 20th</li> <li>✓ 21 SB Indiana at W 6th Ave</li> <li>✓ 22 WB S Golden Rd at Isabel</li> <li>✓ 23 EB W 54th at Marshall</li> <li>✓ 24 SB County HWY 73 @ N Turkey Creek</li> <li>✓ 25 SB Swede Gulch at Evergreen Pkwy</li> </ul>
REVISION HISTORY:	

mc 17



4

3

2

1

NOTES:

- 1. POLE IS BREAKAWAY 2.875" (73mm) IN DIAMETER 6063-T52 ALUMINUM WITH WALL THICKNESS .203" (5.16mm) AS PER 12/6/2007 FHWA LETTER.
- 2. THE PANEL ASSEMBLY MAY NOT EXCEED TWO BATTERY PACKS
- 3. MAX TOTAL WEIGHT OF ASSEMBLY IS 30.8 LBS (13970.63 GRAMS)

REVISION HISTORY			
REV.	DESCRIPTION	DATE	APPROVED
A	INITIAL DRAWING	10/26/2020	

BOM						
Item	Part Number	Part Name	QTY.	MASS (LB)	DIMENSIONS LxWxH (IN)	CROSS-SECTIONAL AREA (FT^2)
1	204-00029	14" BLACK 2-PIECE POLE	1	17	2.9 x 2.9 x 168.0	3.0 (2 FOUNDATION)
2	701-00116	Double Panel - Top Mount	1		21.3 x 28.3 x 10.5	2.1
3	701-0059	Flock Safety Camera	1	3.6	3.3 x 4.3 x 10.5	.3
4	702-0007	RAM Ball Mount & Adapter	1	1.4	N/A	N/A
5	701-00011	Battery Pack	2	4.4	2.8 x 3.9 x 10.8	N/A

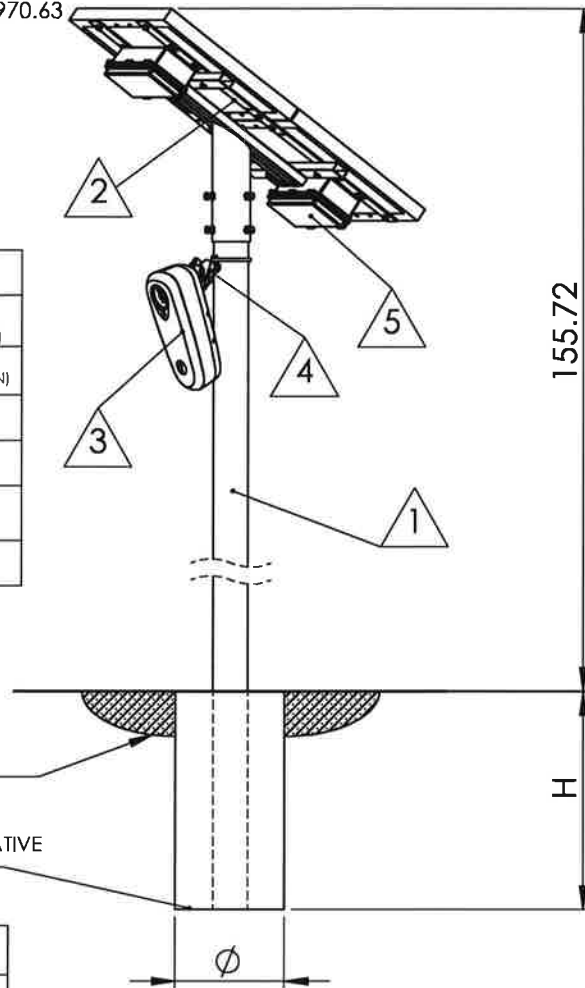

FOUNDATION SPECIFICATIONS				
TYPE	V_MAX (MPH)	CAISSON Ø (IN)	CAISSON H (IN)	SOLAR PANEL ELEVATION FROM GRADE (FT MAX)
1*	85	8	24	12
2	110	12	30	12
3	130	12	36	12
4	150	16	48	12

\* STANDARD INSTALLATION SPECIFICATIONS

**PROPRIETARY AND CONFIDENTIAL**  
 THE INFORMATION CONTAINED IN THIS DRAWING IS THE SOLE PROPERTY OF FLOCK SAFETY. ANY REPRODUCTION IN PART OR AS A WHOLE WITHOUT THE WRITTEN PERMISSION OF FLOCK SAFETY IS PROHIBITED.

DIMENSIONS ARE IN INCHES TOLERANCES: FRACTIONAL: X/16 ANGULAR: X.X±3° X.XX ±1° DECIMAL: X.X±.02 X.XX±.01 X.XXX±.005		NAME	DATE
NEXT ASSY	USED ON	DRAWN	
APPLICATION	DO NOT SCALE DRAWING	CHECKED	
		ENG APPR.	
		MFG APPR.	
		Q.A.	
		COMMENTS:	

**flock safety**  
 TOP POLE MOUNT -  
 DOUBLE SOLAR PANEL  
 WITH 2 EXTERNAL  
 BATTERIES

SIZE **A** DWG. NO. **905-00005** REV. **A**  
 SCALE: 1:20 SHEET 1 OF 1

4

3

2

1

**BOARD OF COUNTY COMMISSIONERS BRIEFING PAPER**  
**License Agreement for a Wildlife Fence in County Right of**  
**Way**  
**September 13, 2022**

For Information       For Discussion/Board Direction       Consent to  
Place on Business/  
Hearing Agenda

**Issue:** The applicant desires to install wildlife fencing along West Ken Caryl Avenue.

**Background:** The Colorado Department of Transportation, (CDOT) has submitted construction plans for roadway improvements for W. Ken Caryl Avenue at C-470, which includes installing and maintaining wildlife fencing.

**Discussion:** Due to the existing topography, steep side slope and for it to be effective, the fence needs to be installed closer to the existing roadway and within county right of way.

**Fiscal Impact:** No fiscal impact to the County. CDOT will maintain in the future.

**Revenue Limits Impact:**    yes    no

**Recommendation:** Staff recommends approval of the License to construct the wildlife fencing and that it be placed on the consent agenda for approval at an upcoming business meeting.

**Originator:** Robert Taylor, Right of Way/Survey Supervisor, T&E, 8459

**Contacts for Additional Information:**

Carey Markel, Assistant County Attorney, 8964

Steve Durian, Director Transportation & Engineering, 8498

**BOARD OF COUNTY COMMISSIONERS BRIEFING PAPER**  
**Appointment of Alternate Members of Opioid Council**  
**September 13, 2022**

For Information       For Discussion/Board Direction       Consent to Place on Business/ Hearing Agenda

**Issue:** The BCC is a party to a Colorado Regional Opioid Intergovernmental Agreement for Region 10, which established the Region 10 Opioid Regional Council, also known as the Gateway to the Rockies Opioid Council or “GROC.” As a member of GROC, the County is responsible for appointing several voting members of GROC, including alternate members.

**Background:** The BCC may appoint as alternates to GROC (1) a county representative, (2) a city representative, (3) a public health representative, (4) a human services department representative, and (5) a law enforcement representative.

**Discussion:** The following are recommended as alternate members of GROC:

- County: Commissioner Andy Kerr
- City: Bud Starker, Mayor, City of Wheat Ridge
- Public Health: Max Johnson, Harm Reduction Supervisor, Jefferson County Public Health
- Human Services: Barb Weinstein, Division Director for Children, Youth and Adult Protection, Jefferson County Human Services Department
- Law Enforcement: Commander Chad Bingham, Jefferson County Sheriff’s Office

**Fiscal Impact:** Not applicable.

**Revenue Limits Impact:** yes no

**SPA Review:** Not applicable.

**Recommendations:** That the Board of County Commissioners appoint the following persons to serve as alternate voting members of the Opioid Regional Council for Region 10:

- County: Commissioner Andy Kerr
- City: Bud Starker, Mayor, City of Wheat Ridge
- Public Health: Max Johnson, Harm Reduction Supervisor, Jefferson County Public Health
- Human Services: Barb Weinstein, Division Director for Children, Youth and Adult Protection, Jefferson County Human Services Department
- Law Enforcement: Commander Chad Bingham, Jefferson County Sheriff’s Office

**Originator:**

Eric Butler, Deputy County Attorney, ext 8929

**Contacts for Additional Information:**

Deborah Churchill, BCC Chief of Staff, ext 8502

Christopher Habgood, Senior Budget Analyst, ext 8571

**BOARD OF COUNTY COMMISSIONERS BRIEFING PAPER  
2022 Organization and Business Item Resolution for  
Board of County Commissioner Modification  
September 13, 2022**

For Information       For Discussion/Board Direction       Consent to  
Place on Business/  
Hearing Agenda

**Issue:** Due to upcoming jeffco.us website enhancements and page redesigns, the 2022 organization resolution needs to be modified to reflect the new public meeting notice location on Jefferson County’s website.

**Background:** At the Board of County Commissioners’ (“Board”) January 18, 2022 meeting, the Board approved Resolution CC22-001 which specifies public notices will be posted on our website at [www.jeffco.us/agendacenter](http://www.jeffco.us/agendacenter).

Recently, Jefferson County purchased a new software solution, eScribe, to replace its existing Granicus solution and CivicPlus Agenda Center solution which are used to conduct public meetings and post public notices. We will need to start directing the public to [www.jeffco.us/meetings](http://www.jeffco.us/meetings) so that they can continue to navigate to public notices on the jeffco.us website.

**Discussion:** To make modification to the 2022 annual organization resolution, CC22-001.

**Fiscal Impact:** None

**Revenue Limits Impact:**     yes       no

**Recommendations:** Modify resolution to reflect new webpage [www.jeffco.us/meetings](http://www.jeffco.us/meetings) for required public notices and said resolution be placed on the September 20, 2022 consent agenda.

**Originator:** Deborah Churchill, Chief of Staff (ext. 8502)

**Contacts for Additional Information:** Deborah Churchill, Chief of Staff (ext. 8502); Julie Story (ext. 8541) and Daniel Collins (ext. 8052).

Commissioner Kerr moved that the following Resolution be adopted:

BEFORE THE BOARD OF COUNTY COMMISSIONERS

OF THE COUNTY OF JEFFERSON

STATE OF COLORADO

RESOLUTION NO. CC22-001

RE: Board of County Commissioners - 2022 Organization and Business Items

**WHEREAS**, at the Board of County Commissioners' ("Board") first regular meeting of each calendar year, the Board holds an organizational meeting at which time the Board elects its Chairman and Chairman Pro Tem, makes its annual appointments to various boards, approves the banks, savings and loan associations and short-term investment banks as official banks and depositories for the handling and safekeeping of Jefferson County monies; and

**WHEREAS**, the Board of County Commissioners desires to make such appointments and approvals as necessary.

**NOW, THEREFORE, BE IT RESOLVED**, that the Board of County Commissioners hereby and herewith elects Commissioner Kerr as Chairman of the Board of County Commissioners of the County of Jefferson, Colorado to serve until a successor is appointed in 2023.

**BE IT FURTHER RESOLVED**, that the Board of County Commissioners hereby and herewith elects Commissioner Kraft-Tharp as Chairman Pro Tem of the Board of County Commissioners of the County of Jefferson, Colorado to serve until a successor is appointed in 2023.

**BE IT FURTHER RESOLVED**, that the Board of County Commissioners hereby and herewith makes the following appointments of representatives to serve until a successor is appointed in 2023:

Commissioner Kerr to the **Boundary Control Commission**, Commissioner Kraft-Tharp as the first alternate and Commissioner Dahlkemper as the second alternate; and

Commissioner Dahlkemper to the **Chatfield Watershed Authority**, and

CC22-001

Page 2

Commissioner Kerr as alternate; and

Commissioner Kerr to the **Colorado Clean Water Coalition** and Pat O'Connell, Engineering Geologist, as alternate; and

Commissioner Kraft-Tharp to the **Colorado Counties, Inc (CCI) Legislative Committee**, provided, however, in case Commissioner Kraft-Tharp is unavailable, Commissioner Kerr will be Jefferson County's designated representative; and

Commissioner Dahlkemper to the **Criminal Justice Coordinating Committee**, and Don Davis, County Manager, as alternate; and

Commissioner Kraft-Tharp as Jefferson County representative to the **Denver Regional Council of Governments (DRCOG)** and Commissioner Kerr as alternate; and

Commissioner Kraft-Tharp to the **First Judicial District Court Services Advisory Board (CSAB)** and Commissioner Kerr will be the alternate; and

Steve Durian, Transportation & Engineering Director, to the **I-70 Collaborative Effort** and Commissioner Kerr as alternate; and

Steve Durian, Transportation & Engineering Director, to the **I-70 Mountain Coalition** and Commissioner Kerr as alternate; and

Commissioner Dahlkemper to the **Jeffco Connections**, and Don Davis, County Manager, as alternate; and

Commissioner Kraft-Tharp to the **Jefferson Center**, and Mary Berg, Human Services Director, as alternate; and

Commissioner Dahlkemper to the **Jefferson County Communities That Care Key Leaders**; and

Commissioner Kerr to the **Jefferson County Corrections Board** and Commissioner Dahlkemper as alternate; and

Commissioner Kraft-Tharp to the **Jefferson County Economic Development Corporation Administrative Committee**; and

Commissioner Kraft-Tharp, Commissioner Kerr, and Commissioner

CC22-001

Page 3

Dahlkemper to the **Jefferson County Economic Development Corporation Board of Directors**; and

Commissioner Kraft-Tharp, Commissioner Kerr, and Commissioner Dahlkemper to the **Jefferson County Economic Development Corporation Board of Governors**; and

Commissioner Kraft-Tharp to the **Jefferson County Emergency Communications Authority (JCECA) Board**; provided, however, in case Commissioner Kraft-Tharp is unavailable, Chief JD Jepkema will be Jefferson County's alternate representative; and

Commissioner Kerr to the **Jefferson County Head Start Policy Council**, and Mary Berg, Human Services Director, as alternate; and

Commissioner Kraft-Tharp as Chairman of the **Jefferson County Transportation Action and Advocacy Group (JEFFTAAG)** and Commissioner Kerr as Chairman Pro Tem; and

Commissioner Dahlkemper to the **Jefferson Parkway Public Highway Authority Board (JPPHA)** and Commissioner Kraft-Tharp as alternate; and

Commissioner Kerr to the **Metro Area County Commissioners (MACC)** and Commissioner Kraft-Tharp as alternate; and

Commissioner Kraft-Tharp to the **Mile High Flood District**; and

Commissioner Kraft-Tharp, Commissioner Kerr, and Commissioner Dahlkemper as the **Noxious Weed Advisory Board**; and

Commissioner Dahlkemper to the **Opioid Regional Council**; and

Commissioner Kerr as Director, and Pat O'Connell, Engineering Geologist, as the first alternate to the **Rocky Flats Stewardship Council**; and

Commissioner Kraft-Tharp to the **Rocky Mountain Metropolitan Airport Community Noise Roundtable** and Commissioner Dahlkemper as alternate; and

Commissioner appointments for **Urban Renewal Districts** will correspond with Commissioner's district boundaries; and

CC22-001

Page 4

Commissioner Dahlkemper to the **WestConnect Corridor Coalition**, and Commissioner Kerr as alternate.

**BE IT FURTHER RESOLVED**, that the Board approves and designates, as authorized depositories for the Jefferson County funds, all financial institutions in the State of Colorado that have been designated by the State Bank Commissioners or State Commissioner of Savings and Loan Associations as eligible public depositories.

**BE IT FURTHER RESOLVED**, that such eligible public depositories as are located within Jefferson County shall continue to receive first preference as depositories for Jefferson County funds.

**BE IT FURTHER RESOLVED**, per C.R.S. 24-6-402.3, the Board designates <https://www.jeffco.us/AgendaCenter> as the posting location for public meeting notices and agenda information of the Board; and, should <https://www.jeffco.us/AgendaCenter> be unavailable due to exigent or emergency circumstances, the Board designates the glass enclosures outside of Hearing Room 1 of the Administration and Courts Facility, 100 Jefferson County Parkway, Golden, Colorado as the posting location.

Commissioner Kraft-Tharp seconded the adoption of the foregoing Resolution. The roll having been called, the vote was as follows:

Commissioner Andy Kerr	Aye
Commissioner Tracy Kraft-Tharp	Aye
Commissioner Lesley Dahlkemper, Chairman	Aye

The Resolution was adopted by unanimous vote of the Board of County Commissioners of the County of Jefferson, State of Colorado.

Dated: January 18, 2022